

STEREO CASSETTE DECK KX-390/490

SERVICE MANUAL

CENTER

KX-390/490

IMPORTANT NOTICE

This manual has been provided for the use of authorized YAMAHA Retailers and their service personnel. It has been assumed that basic service procedures inherent to the industry, and more specifically YAMAHA Products, are already known and understood by the users, and have therefore not been restated.

WARNING: Failure to follow appropriate service and safety procedures when servicing this product may result in personal injury, destruction of expensive components, and failure of the product to perform as specified. For these reasons, we advise all YAMAHA product owners that any service required should be performed by an authorized YAMAHA Retailer or the appointed service representative.

IMPORTANT: The presentation or sale of this manual to any individual of firm does not constitute authorization, certification or recognition of any applicable technical capabilities, or establish a principle-agent relationship of any form.

The data provided is believed to be accurate and applicable to the unit(s) indicated on the cover. The research, engineering, and service departments of YAMAHA are continually striving to improve YAMAHA products. Modifications are, therefore, inevitable and specifications are subject to change without notice or obligation to retrofit. Should any discrepancy appear to exist, please contact the distributor's Service Division.

WARNING: Static discharges can destroy expensive components. Discharge any static electricity your body may have accumulated by grounding yourself to the ground buss in the unit (heavy gauge black wires connect to this buss).

IMPORTANT: Turn the unit OFF during disassembly and part replacement. Recheck all work before you apply power to the unit.

■ CONTENTS

TO SERVICE PERSONNEL	1	SCHEMATIC DIAGRAM (KX-390)	16
WARNING	1	SCHEMATIC DIAGRAM (KX-490)	17
FRONT PANELS	1	PRINTED CIRCUIT BOARD (KX-490)	18~21
REAR PANELS	1	SCHEMATIC DIAGRAM (Mechanism) (KX-490)	22
DISASSEMBLY PROCEDURES (KX-390)	3,4	DISASSEMBLY PROCEDURES (KX-490)	23,24
SPECIFICATIONS (KX-390)	5	SPECIFICATIONS (KX-490)	25
DIMENSIONS (KX-390)	5	DIMENSIONS (KX-490)	25
INTERNAL VIEW (KX-390)	5	INTERNAL VIEW (KX-490)	25
ADJUSTMENTS (KX-390)	6~9	ADJUSTMENTS (KX-490)	26~29
μ-COM DATA (KX-390)	10	μ-COM DATA (KX-490)	30
BLOCK DIAGRAM (KX-390)	11	BLOCK DIAGRAM (KX-490)	31
PRINTED CIRCUIT BOARD (KX-390)	12~14	PARTS LIST	32~50
SCHEMATIC DIAGRAM (Mechanism) (KX-390)	15		

100540

100547

YAMAHA
YAMAHA CORPORATION
P.O.Box1.Hamamatsu.Japan

2.9K-791 (PM) Printed in Japan '96.3

KX-390**KX-490****TO SERVICE PERSONNEL****1. Critical Components Information.**

Components having special characteristics are marked Δ and must be replaced with parts having specifications equal to those originally installed.

2. Leakage Current Measurement (For 120 V Model Only).

When service has been completed. It is imperative that you verify that all exposed conductive surfaces are properly insulated from supply circuits.

- Meter impedance should be equivalent to 1500 ohms shunted by 0.15 μ F.
- Leakage current must not exceed 0.5 mA.
- Be sure to test for leakage with the AC plug in both polarities.

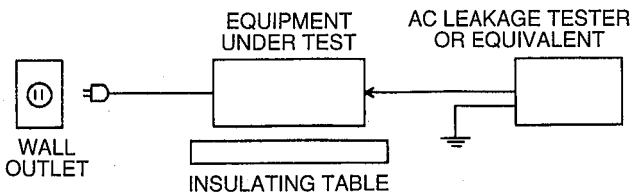
**DOLBY B-C / DOLBY B-C-S**

Dolby noise reduction and HX PRO headroom extension manufactured under license from Dolby Laboratories Licensing Corporation. HX PRO originated by Bang and Olufsen. "Dolby", the double-D symbol and "HX PRO" are trademarks of Dolby Laboratories Licensing Corporation.

WARNING: CHEMICAL CONTENT NOTICE!

The solder used in the production of this product contains LEAD. In addition, other electrical/electronic and/or plastic (where applicable) components may also contain traces of chemicals found by the California Health and Welfare Agency (and possibly other entities) to cause cancer and/or birth defects or other reproductive harm.

DO NOT PLACE SOLDER. ELECTRICAL/ELECTRONIC OR PLASTIC COMPONENTS IN YOUR MOUTH FOR ANY REASON WHATSOEVER!

Avoid prolonged, unprotected contact between solder and your skin! When soldering, do not inhale solder fumes or expose eyes to solder/flux vapor!

If you come in contact with solder or components located inside the enclosure of this product, wash your hands before handling food.

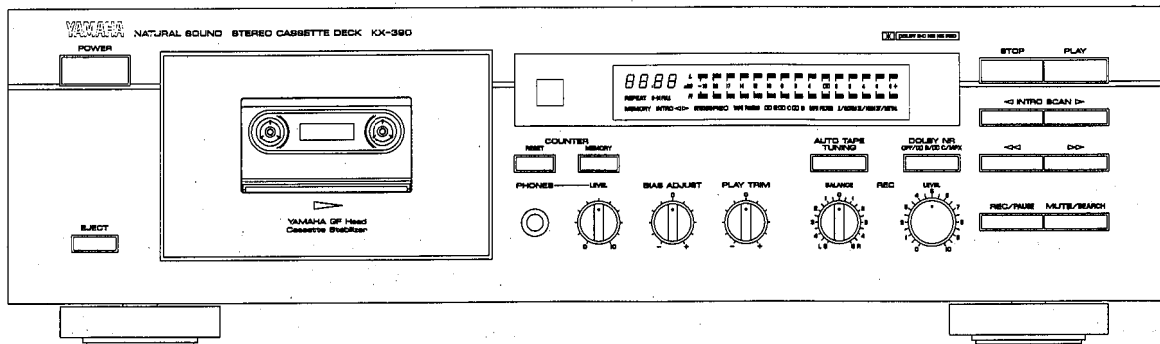
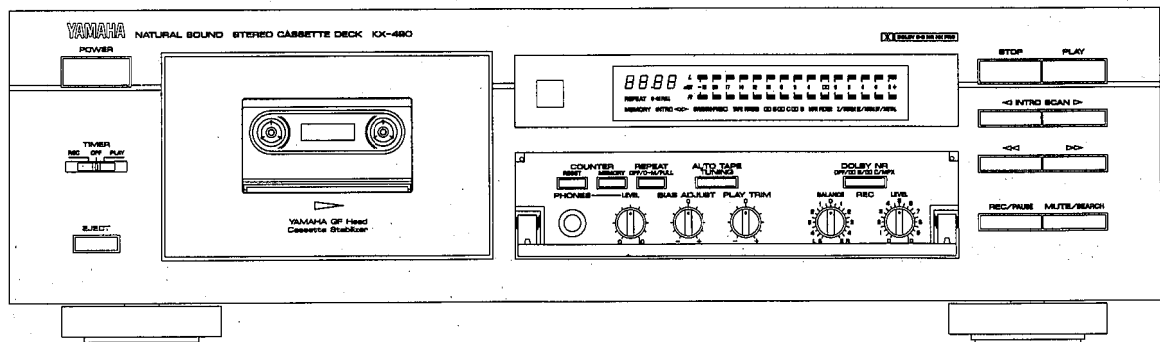
FRONT PANELS**● KX-390****● KX-490****KX-390/490**

REAR PANELS

● **U,C models**
(KX-390 Only)

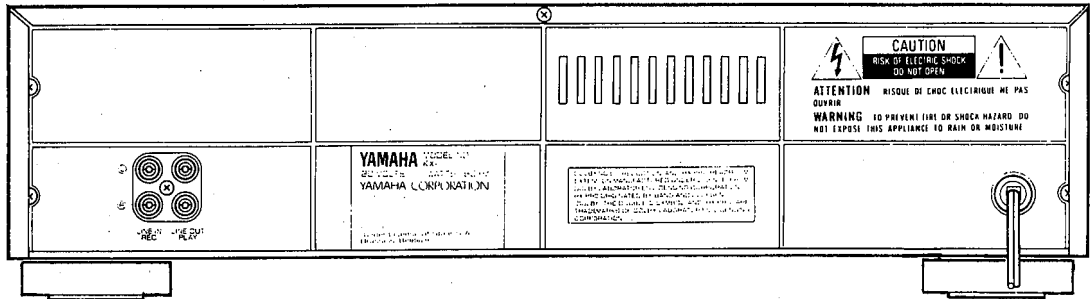

● **A model**

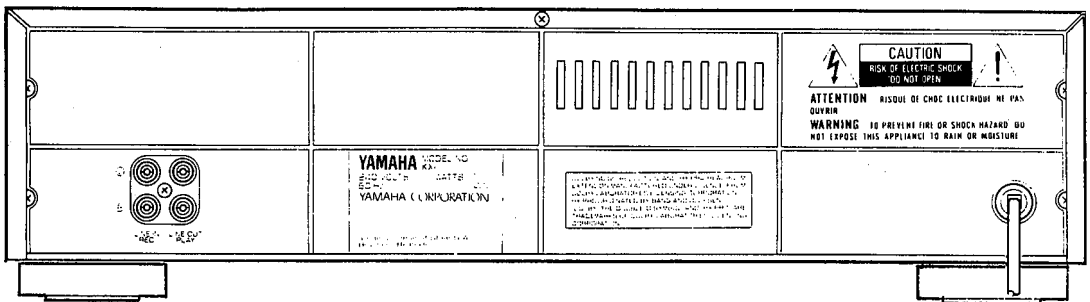

● **B,G models**

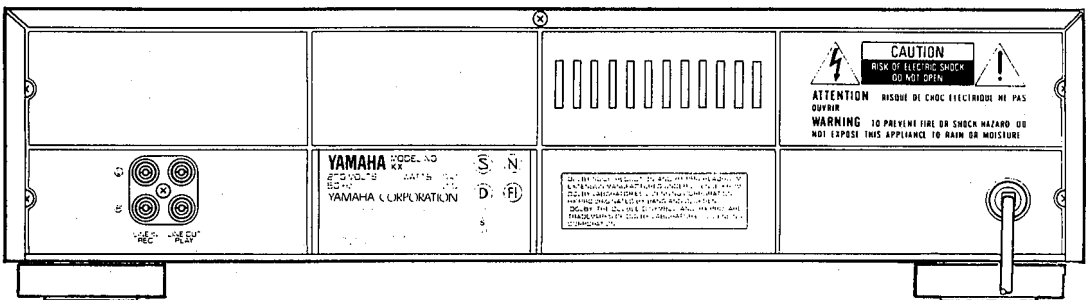

● **R model**

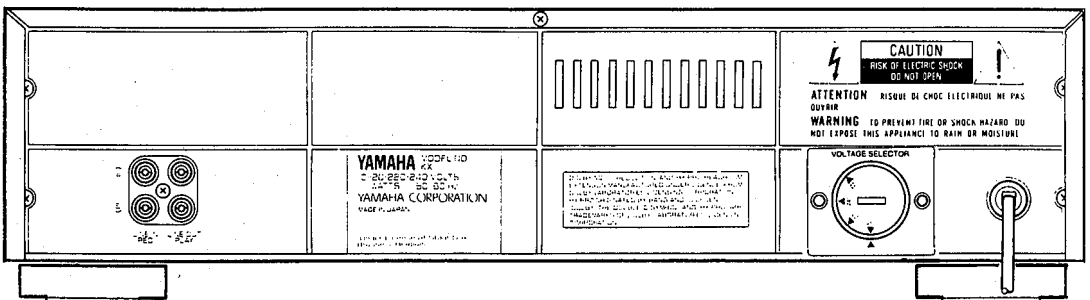

DISASSEMBLY PROCEDURES

(Remove parts in disassembly order as numbered)

1. Removal of Top Cover

- a. Remove 5 screws (①, ②) in fig. 1.

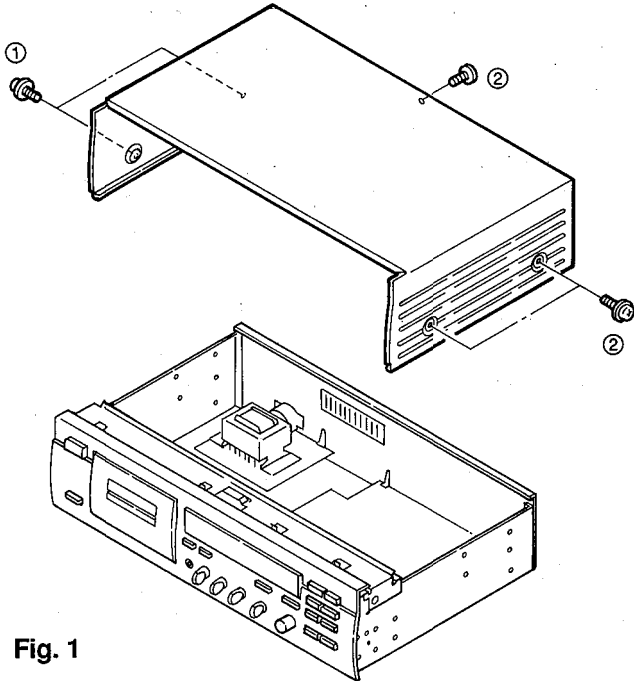

Fig. 1

2. Removal of Front Panel

- a. Remove 6 screws (③) in fig. 2.
- b. Remove 5 knobs (A, B) in fig. 2.
- c. Detach the hook and remove the main circuit board (4).
- d. Remove 1 connector (#3).

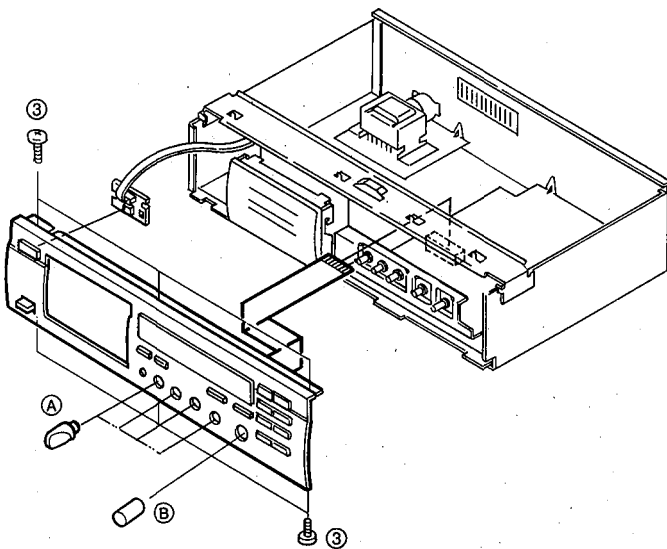

Fig. 2

3. Removal of Cassette Mechanism Unit

- a. Remove 4 screws (④) in fig. 3.
- b. Remove the cassette mechanism unit after sliding it toward the back.
- c. Remove 3 connectors (#1, #2, #5).

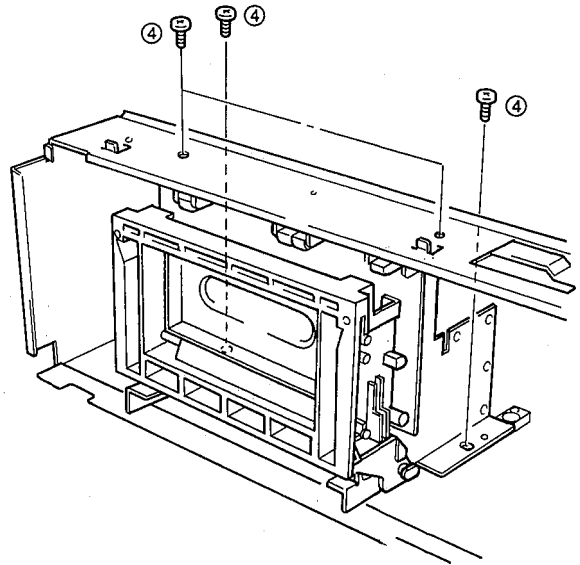

Fig. 3

4. Removal of Housing Ass'y

- a. Detach the spring in fig. 4.
- b. Remove lower part of the housing ass'y by pressing it to outside.
- c. Remove the housing ass'y from the damper arm.

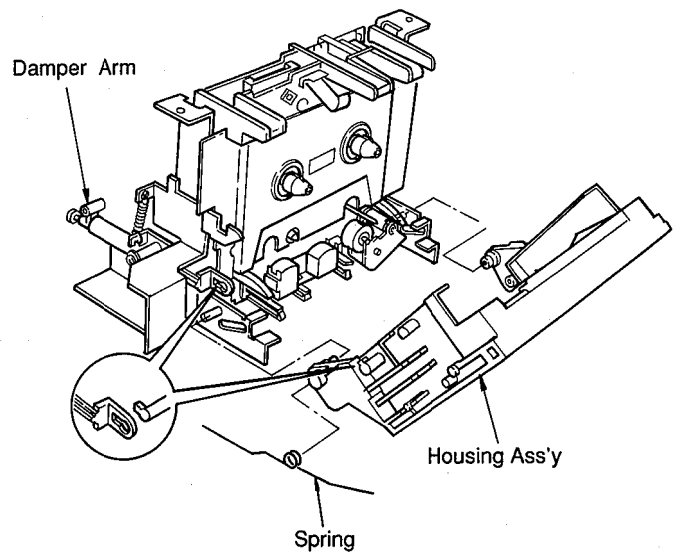

Fig. 4

5. Removal of Pinch Roller

a. Detach the hook in fig. 5 and remove the pinch roller.

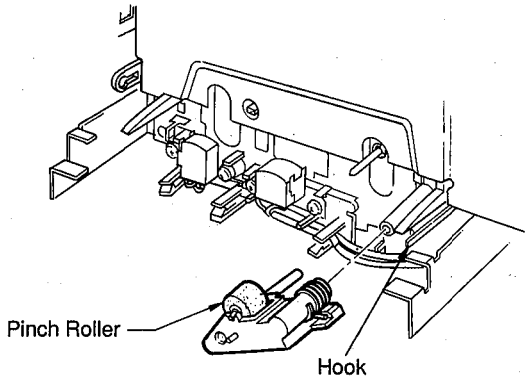

Fig. 5

8. Removal of Main Motor

a. Remove 2 screws (⑧) in fig. 8 and then remove the motor.

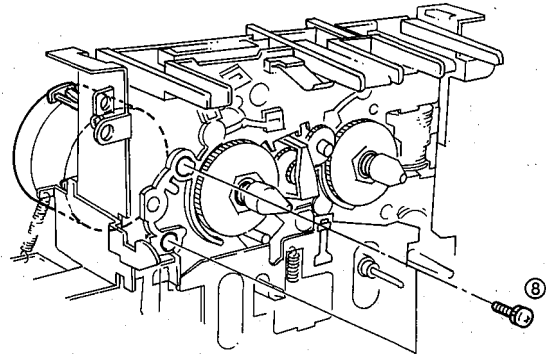

Fig. 8

6. Removal of Heads

a. Remove 2 screws (⑤) in fig. 6 and then remove the Recording/Playback Head.
 b. Remove 2 screws (⑥) in fig. 6 and then remove the Erase Head.

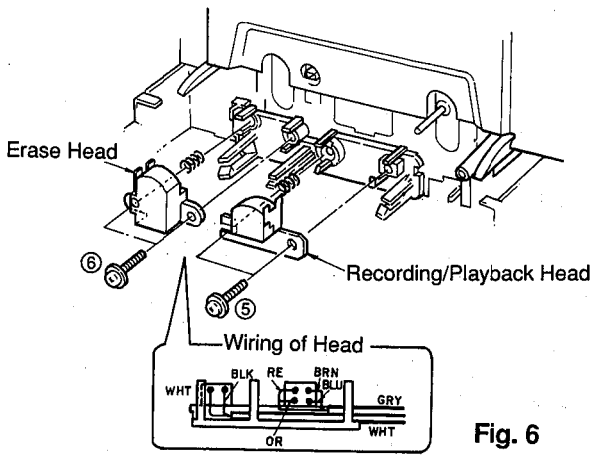

Fig. 6

9. Removal of Main Circuit Board(1)

a. Remove 4 screws (⑨) and detach 2 hooks in fig.9.

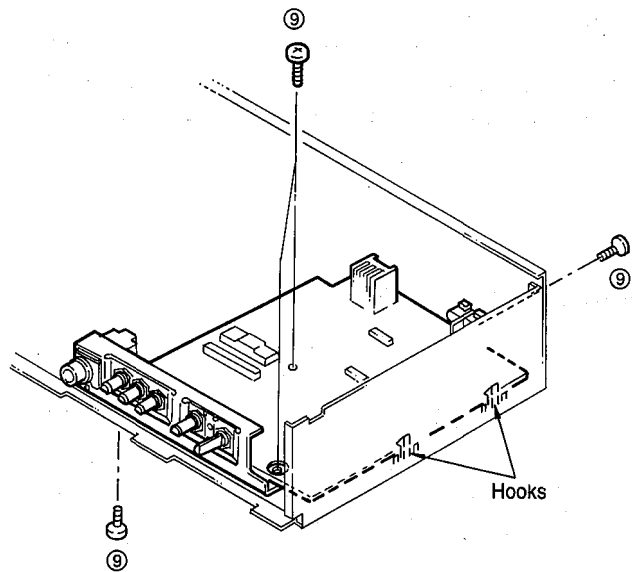

Fig. 9

7. Removal of Back Plate

a. Remove 1 screw (⑦) and 1 plastic rivet (©) in fig.7 and then remove the back plate.

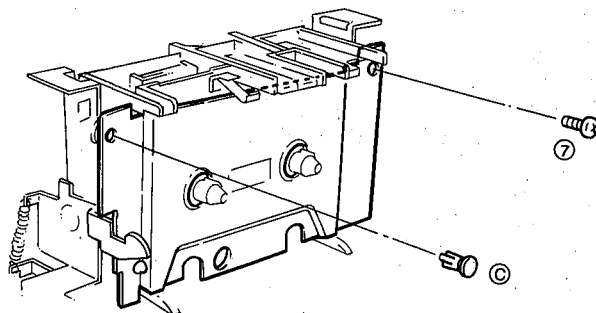
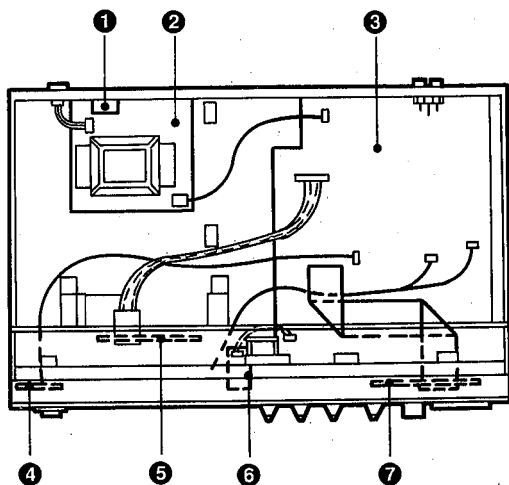

Fig. 7

■ SPECIFICATIONS

Track Configuration 4 track, 2 channel stereo
 Motor DC servo motor
 Heads ... Recording/Playback: GF Hard permalloy head
 Erase: Double-gap Ferrite head
 Rapid Transport 100 sec. (C-60)
 Wow and Flutter
 WRMS 0.07%
 W.Peak ±0.12%
 Signal-to-Noise Ratio
 Dolby NR off 58 dB
 Dolby B on 66 dB
 Dolby C on 74 dB
 Frequency Response
 Normal tape (-20 dB) 20 - 16,000 Hz ±3 dB
 High tape (-20 dB) 20 - 17,000 Hz ±3 dB
 Metal tape (-20 dB) 20 - 19,000 Hz ±3 dB
 Harmonic Distortion(315Hz 160nwb/m(-4dB))
 0.8%
 Input Sensitivity/Impedance
 Line 100mV/50 k-ohms
 Output Level
 Line 570 mV/1 k-ohms
 Phones 1.5mW/8 ohms
 Channel Separation(1 kHz) 40 dB
 Cross Talk(125 Hz) 55 dB
 Remote Control Custom Code 7F

■ INTERNAL VIEW



GENERAL

Power Supplies

U.S.A. and Canadian models 120V, 60Hz
British and European models 230V, 50Hz
Australian model 240V, 50Hz
General model 110/120/220/240V, 50/60Hz

Power Consumption 12 W

Dimensions (W x H x D) 435 x 126 x 285 mm
 (17-1/8" x 5" x 11-3/16")

Weight 4.4 kg (9 lbs. 11 oz)

U U.S.A. model G European model
 C Canadian model B British model
 A Australian model R General model

* Specifications are subject to change without notice.

■ DIMENSIONS

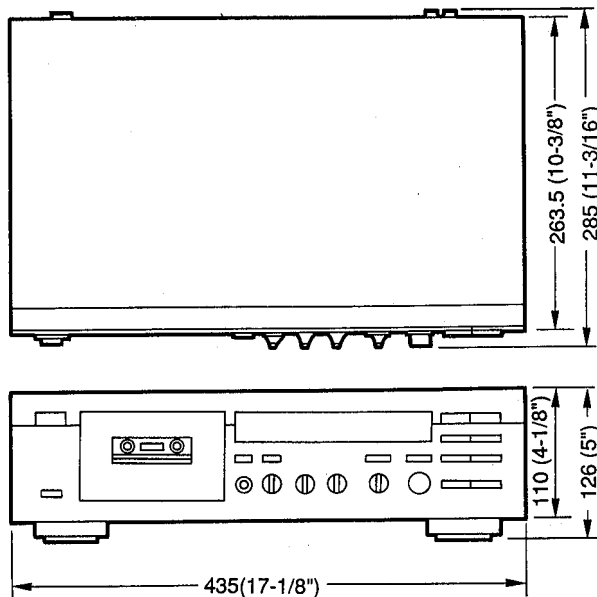

unit: mm (inch)

- ① VOLTAGE SELECTOR (R model only)
- ② POWER TRANSFORMER CIRCUIT BOARD
- ③ MAIN CIRCUIT BOARD (1)
- ④ MAIN CIRCUIT BOARD (4)
- ⑤ CONTROL CIRCUIT BOARD
- ⑥ MAIN CIRCUIT BOARD (3)
- ⑦ MAIN CIRCUIT BOARD (2)

ADJUSTMENTS

1. Before Adjustment:

- Make sure that AC line voltage is within:

Models	AC line voltage
U, C	120 V ± 10%
G, B	230 V ± 10%
A,	240 V ± 10%

- Since head magnetization, dust accumulation, etc. are likely to cause errors in the various characteristics, it is very important to keep the heads properly demagnetized and clean.

2. Instruments required

- Audio frequency oscillator (AF OSC)
- ACVM or dual channel ACVM
- Wow/flutter meter
- Torque meter
TW-2111A (TX911580): FWD. Torque & Back Tension Torque
CT160L (TX911120): FF. Torque & REW. Torque
- DCVM
- Oscilloscope

3. Test tape required

- MTT-111N (TX911650): Tape Speed (3 kHz)
- MTT-114N (TX911680): Azimuth (10 kHz)
- MTT-212N (TX911660): Playback Level (250nWb/m)
- MTT-256 (TX911300): Playback Frequency Response (Normal)
- MTT-356 (TX911310): Playback Frequency Response (High)
- Reference tape
Normal(LH) : TDK AC225(VU167200)
High(CrO₂) : TDK AC514(VU167300)
METAL : TDK AC713(VU167400)

4. Data backup at power off (AC plug)

μ-COM backup data (about 2 weeks): Power ON/OFF, NR (MPX) MODE, TAPE COUNTER VALUE, TAPE TUNING

MECHANISM ADJUSTMENT

Note: The damper must be removed before you perform steps 1 and 2 of the procedure, because the torque meter is hidden behind the damper (Fig. a).

* How to remove the damper from the housing ass'y.

1. Depress the damper with fingers, and the damper can be removed from the shaft in fig. b
2. Take out the damper, lifting it up.

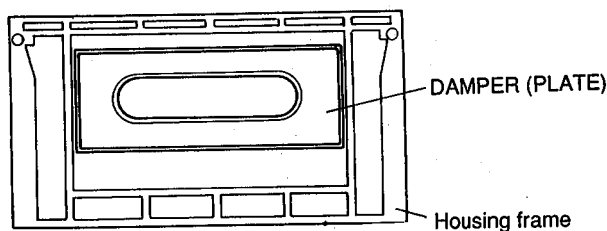

The lid panel is removed

Fig. a

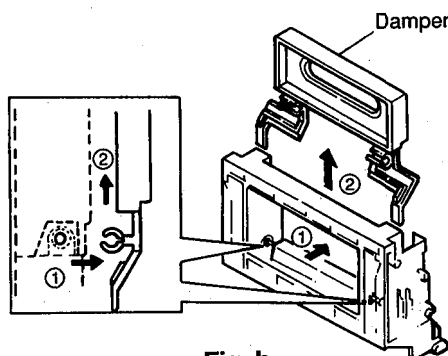

Fig. b

0 dB = 250 nWb/m (315 Hz) = -5 dBV (Line out terminal level)

Step	Item to be Adjusted	Tape	Instrument required	Mode	Adjustment part	Rating	Remarks
1	Check each torque		Torque meter TW-2111A CT160L	PLAY FF REW		Take-up torque: 25 g·cm~70g·cm Back tension: 1.5g·cm~6g·cm FF, REW torque: more than 70g·cm	
2	Check FF, REW take up time	AC-225 (C-60)		FF REW		90 ± 15 seconds	
3	Azimuth	MTT-114 (10 kHz, -10 dB)	ACVM Oscilloscope	PLAY	Azimuth adjustment screw (Fig. A)	Playback level is maximum and phase difference should be minimum. (Fig. B)	After the adjustment make sure to apply screw lock paint.

KX-390/490

Step	Item to be Adjusted	Tape	Instrument required	Mode	Adjustment part	Rating	Remarks
4	Tape speed	MTT-111N 3 kHz, -10 dB	Wow/flutter meter of Frequency counter	PLAY	Potentiometer at the back of the capstan motor. (Fig. C)	3005 Hz \pm 15Hz	• Perform adjustment at the position where the test tape is advanced/rewound to the middle.
5	Wow/flutter	MTT-111N 3 kHz, -10 dB	Wow/flutter meter	PLAY		Less than 0.14% (EIAJ, WRMS)	

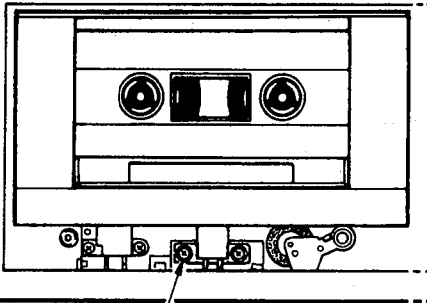

Azimuth adjustment screw

Fig. A

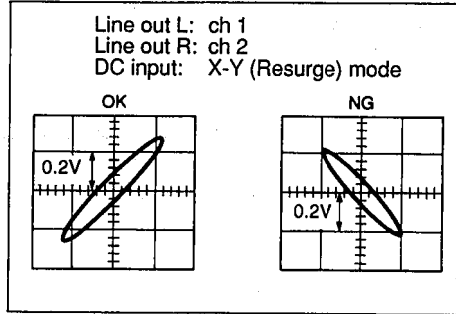

Fig. B

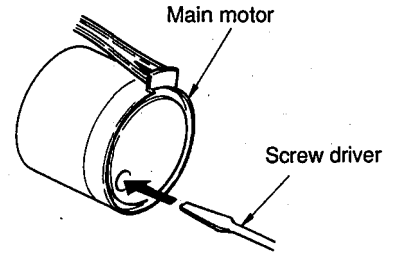

Fig. C

■ ELECTRICAL ADJUSTMENT

* Standard level of this machine is that 250 nWb/m is 0 dB. (-5 dBV at LINE OUT)

● PLAYBACK ADJUSTMENT

Step	Adjustment items	Tape	Instrument required	Mode	Adjustment part	Point of measurement	Adjustment method	Specification
1	Playback Level (315 Hz)	MTT-212N (0 dB)	ACVM	PLAY	VR3 (Lch) VR4 (Rch)	LINE OUT	When MTT-212N is played back, adjust VR so that output level becomes the specified Value.	-5dBV \pm 0.3 dBV
2	Playback EQ Level (10 kHz)	MTT-114N (10 kHz, -10 dB)	ACVM	PLAY	VR1 (Lch) VR2 (Rch)	LINE OUT	When MTT-114N is played back, adjust VR so that output level becomes the specified Value.	-15dBV \pm 1 dBV
3	Confirmation of Playback Frequency Response	MTT-256 (Normal: 3180) μ s + 120 μ s) MTT-356 (High: 3180 μ s + 70 μ s)	ACVM Oscilloscope	PLAY		LINE OUT	Make sure that level of LINE OUT jack is within the specification of Fig. D when test tape is played back.	0 dB \pm 4 dB

● PLAYBACK FREQUENCY RESPONSE

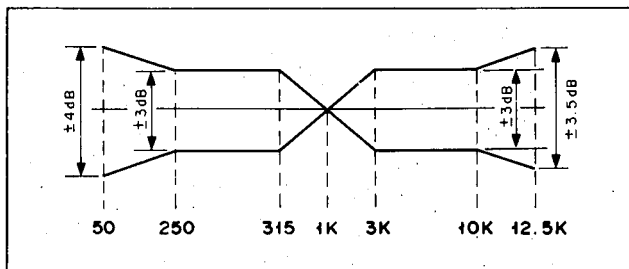

Fig. D

● RECORDING ADJUSTMENT
(BIAS ADJ. VR and PLAY TRIM VR Center position, if not specified otherwise)

Step	Adjustment Items	Test tape	Instrument required	Mode	Adjustment Terms	Measurement point	Adjustment point	Rating
1	Meter Level	Normal (AC225) (LH)	ACVM AF OSC	REC/ PAUSE PEAK HOLD OFF TEST MODE	1. Set FL display test mode to meter peak hold OFF. 2. Set REC LEVEL knob to maximum. 3. Input 315 Hz signal to LINE IN jack from AF OSC. Adjust output level of AF OSC so that the level of LINE OUT jack becomes -5 dBV.	Peak Level Meter	VR9 (Lch) VR10 (Rch)	Adjust VR to the minimum level where 0 dB segment (red) of peak level meter lights up.
2	Bias Oscillation Level (HXPRO)	HIGH (AC514) (CrO ₂)	DCVM	REC	1. Enter REC mode. 2. Connect DCVM between each TP-GND.	TP1-GND TP2-GND	L3 (Lch) L4 (Rch)	Adjust L3 and L4 so that DC voltage becomes minimum.
3	Recording Level	HIGH (AC514) (CrO ₂)	ACVM AF OSC	REC/ PAUSE	1. Set REC LEVEL knob to maximum. 2. Enter REC/PAUSE mode. 3. Input 315 Hz signal to LINE IN jack from AF OSC. Adjust the output level of AF OSC so that level of LINE OUT jack becomes -25 dBV.	LINE OUT	VR5 (Lch) VR6 (Rch)	Adjust VR so that level of LINE OUT jack becomes -25 ± 0.3dBV at playback.
				REC	4. Record the above-mentioned signal.			
				PLAY-BACK	5. Playback the recorded tape.			
4	Recording Bias	Normal (LH) High (CrO ₂) and METAL	ACVM AF OSC	REC/ PAUSE	1. Set REC LEVEL knob to maximum. 2. Enter REC/PAUSE mode. 3. Input 12.5 kHz signal to LINE IN jack from AF OSC. Adjust the output level of AF OSC so that level of LINE OUT jack becomes -25 dBV.	LINE OUT	VR7 (Lch) VR8 (Rch)	Adjust VR so that level of LINE OUT jack satisfies Fig. E when a tape, recorded at -25 ± 0.5 dBV at each frequency, is playback.
				REC	4. Record the above-mentioned signal.			
				PLAY-BACK	5. Playback the recorded tape.			

● TOTAL FREQUENCY RESPONSE (-15dBV)

Table 1

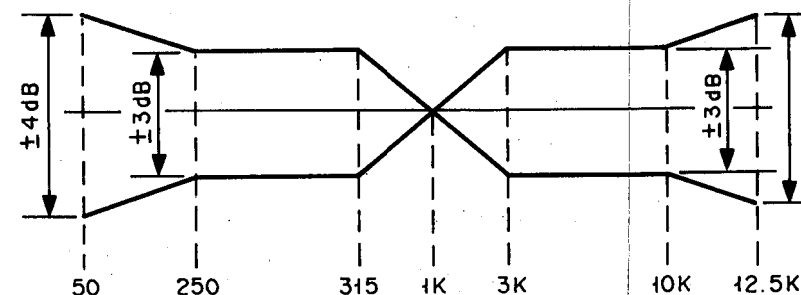

NR : NR off/Dolby B NR on/Dolby C NR on
(B&C NR : Reference level must be recorded level.)
TAPE : Normal(LH)/High(CrO₂)/METAL

Fig.E

● TEST POINT

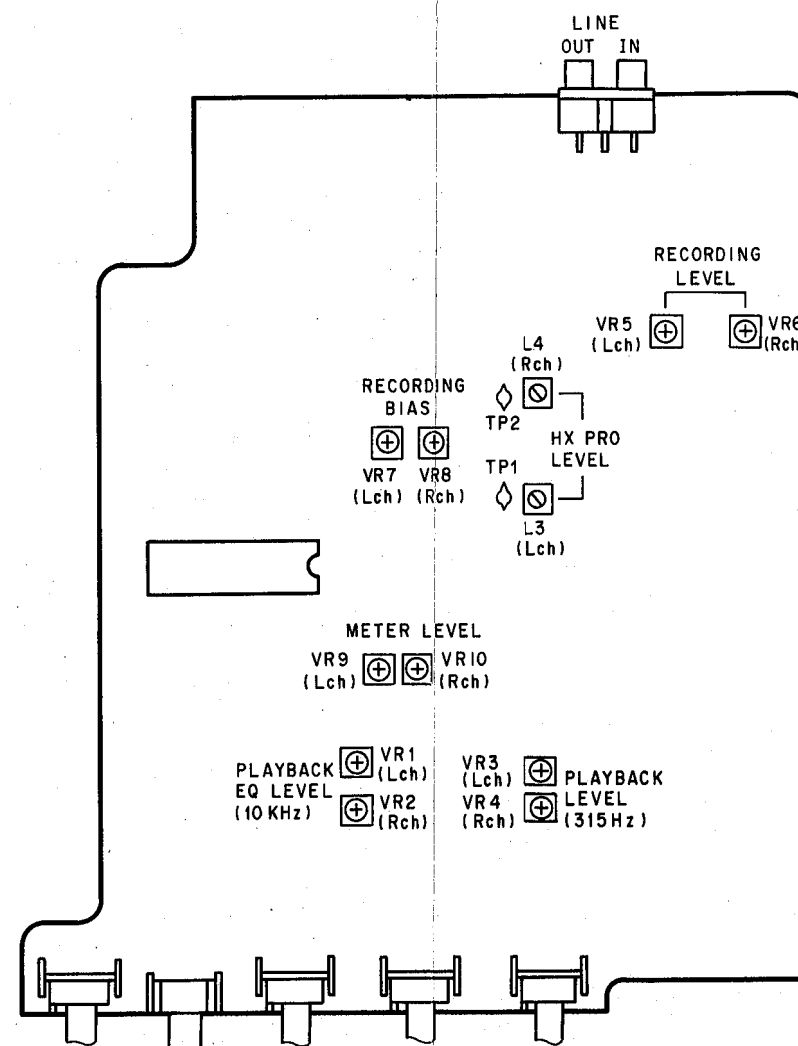

FL DISPLAY TEST MODE

Enter the TEST MODE by pressing POWER SW while pressing the RESET KEY when the power is OFF.

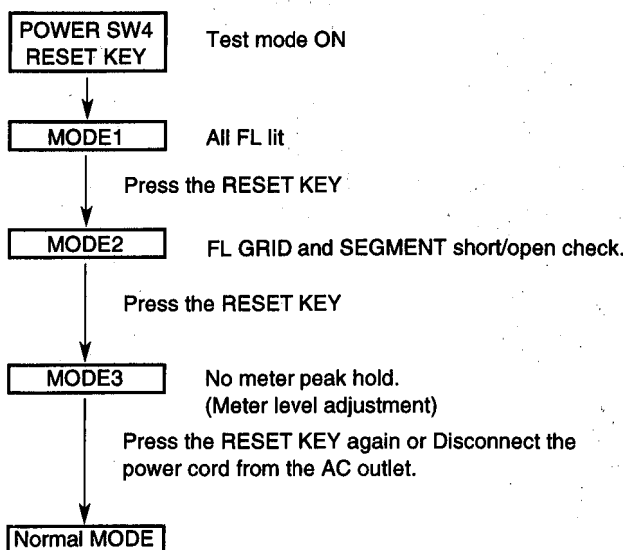

μ-COM DATA
IC13 : LC65204A
4 bit μ-COM

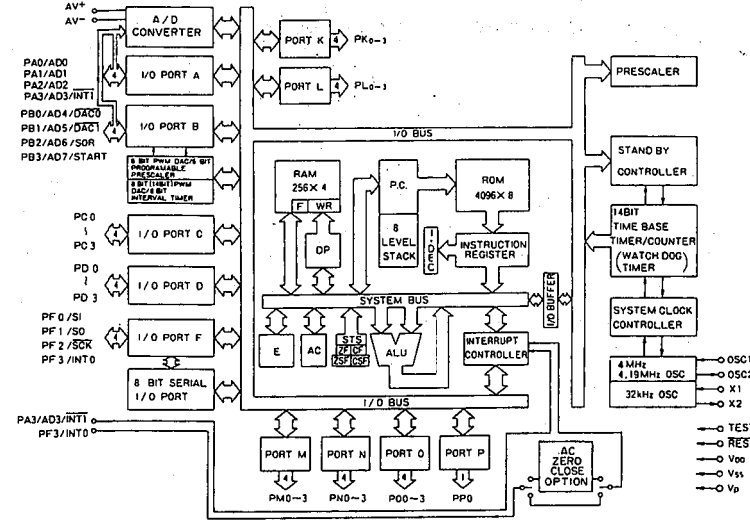
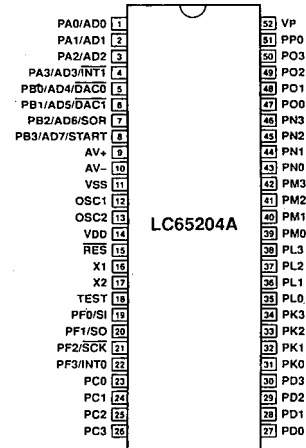

NO	PORT	FUNCTION	LOGIC	NO	PORT	FUNCTION	LOGIC
1	PA0	OPERATION KEY (1)	A/D	27	PD0	LINE MUTE	H:ON
2	PA1	OPERATION KEY (2)	A/D	28	PD1	REC MUTE	H:ON
3	PA2	METER INPUT (L)	A/D	29	PD2	DOLBY 1 (DOLBY ON/OFF)	H:OFF
4	PA3	METER INPUT (R)	A/D	30	PD3	DOLBY 2 (DOLBY C ON/OFF)	H:OFF
5	PB0	MECHA SW	A/D	31	PK0	MPX FILTER	H:ON
6	PB1	MECHA SW & TIMER	A/D	32	PK1	REC/PB SELECT	H:PB
7	PB2	REEL PULSE		33	PK2	FL FILAMENT ON/OFF	H:ON
8	PB3	POWER PULSE		34	PK3	FL SEGMENT 9	H:ON
9	AV+	+5V		35	PL0	FL SEGMENT 8	H:ON
10	AV-	GND		36	PL1	FL SEGMENT 7	H:ON
11	VSS	GND		37	PL2	FL SEGMENT 6	H:ON
12	OSC1	4MHz		38	PL3	FL SEGMENT 5	H:ON
13	OSC2	4MHz		39	PM0	FL SEGMENT 4	H:ON
14	VDD	+5V		40	PM1	FL SEGMENT 3	H:ON
15	RES	RESET		41	PM2	FL SEGMENT 2	H:ON
16	X1	+5V		42	PM3	FL SEGMENT 1	H:ON
17	X2	OPEN		43	PN0	FL DIGIT 1	H:ON
18	TEST	GND		44	PN1	FL DIGIT 2	H:ON
19	PF0	PORT EXPANDER IC (CLOCK)		45	PN2	FL DIGIT 3	H:ON
20	PF1	PORT EXPANDER IC (DATA)		46	PN3	FL DIGIT 4	H:ON
21	PF2	BIAS	H:ON	47	PO0	FL DIGIT 5	H:ON
22	PF3	REMOCON INPUT		48	PO1	FL DIGIT 6	H:ON
23	PC0	MECHA DRIVE	CM	49	PO2	FL DIGIT 7	H:ON
24	PC1	MECHA DRIVE	SOLENOID	50	PO3	FL DIGIT 8	H:ON
25	PC2	MECHA DRIVE	REEL FF	51	PP0	FL DIGIT 9	H:ON
26	PC3	MECHA DRIVE	REEL REW	52	Vp	-21V	

● OUTPUT OF EXPANDER (IC14) PORT

4 PIN	LH	L:ON	10 PIN	LEVEL 3
5 PIN	HIGH	L:ON	11 PIN	LEVEL 4
6 PIN	METAL	H:ON	12 PIN	BIAS 1
7 PIN	TAPE TUNING	H:OFF	13 PIN	BIAS 2
8 PIN	LEVEL 1		14 PIN	BIAS 3
9 PIN	LEVEL 2		15 PIN	BIAS 4

● CONDITION OF OUTPUT PORT VERSUS MODE

NO	NAME	STOP	PLAY	FF/REW	SEARCH	REC PAUSE	REC
21	BIAS	L	L	L	L	L	H
27	LINE MUTE	H	L	H	H	L	L
28	REC MUTE	H	H	H	H	H	L
32	REC/PB SELECT	H	H	H	H	L	L

■ BLOCK DIAGRAM

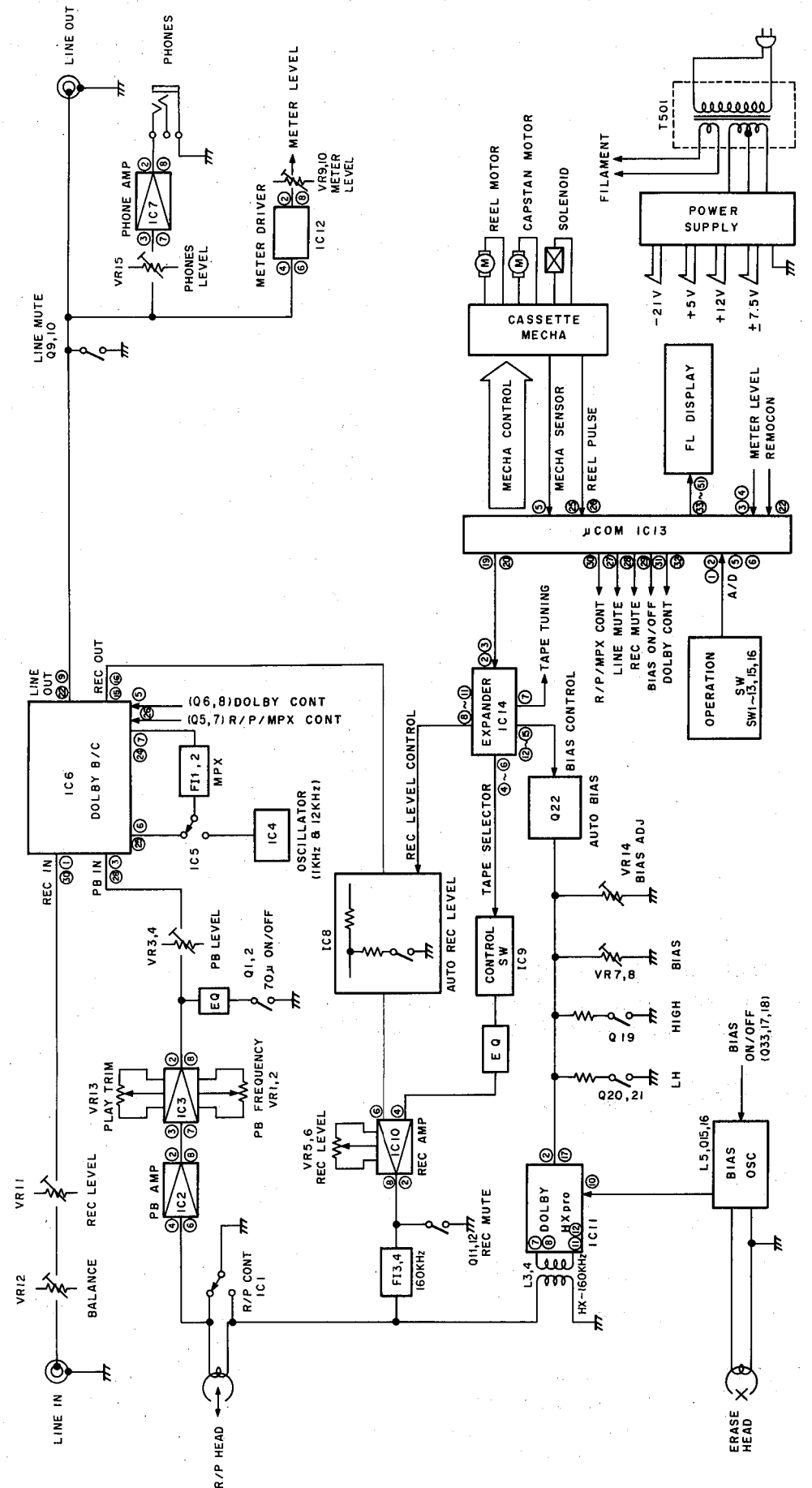

DISASSEMBLY PROCEDURES

(Remove parts in disassembly order as numbered)

1. Removal of Top Cover

- a. Remove 5 screws (①, ②) in fig. 1.

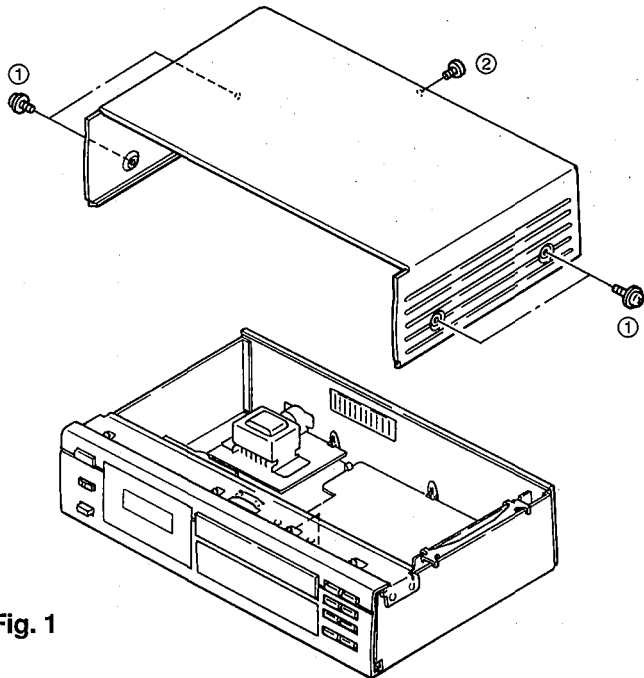

Fig. 1

2. Removal of Front Panel

- a. Remove 6 screws (③) in fig. 2.
- b. Remove 5 knobs (A) in fig. 2 after opening the sub panel.
- c. Remove 1 plastic rivet (B) in fig. 2 and then remove the main circuit board (4).
- d. Remove 1 connector (#3).

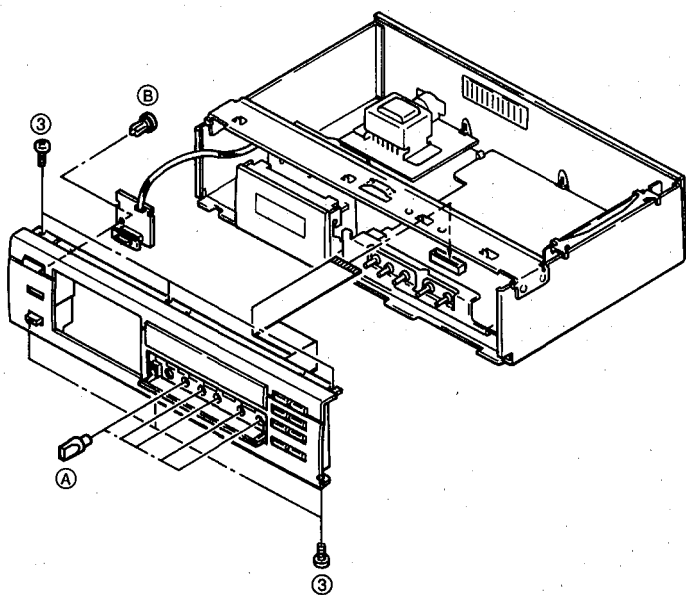

Fig. 2

3. Removal of Cassette Mechanism Unit

- a. Remove 4 screws (④) in fig. 3.
- b. Remove the cassette mechanism unit after sliding it toward the back.

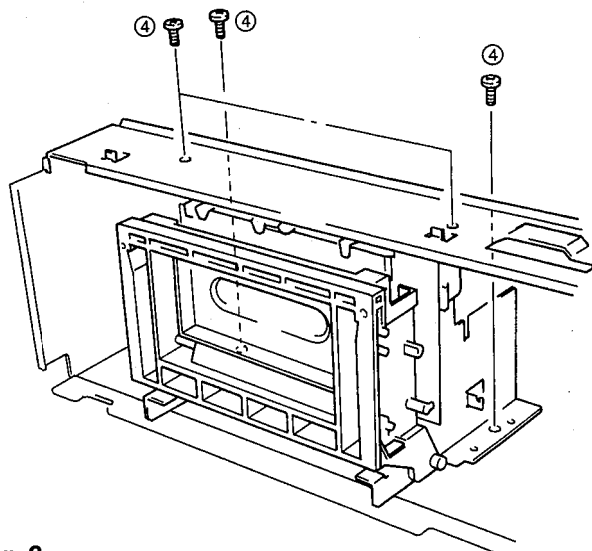

Fig. 3

4. Removal of Housing Ass'y

- a. Detach the spring in fig. 4.
- b. Remove lower part of the housing ass'y by pressing it to outside.
- c. Remove the housing ass'y from the damper arm.

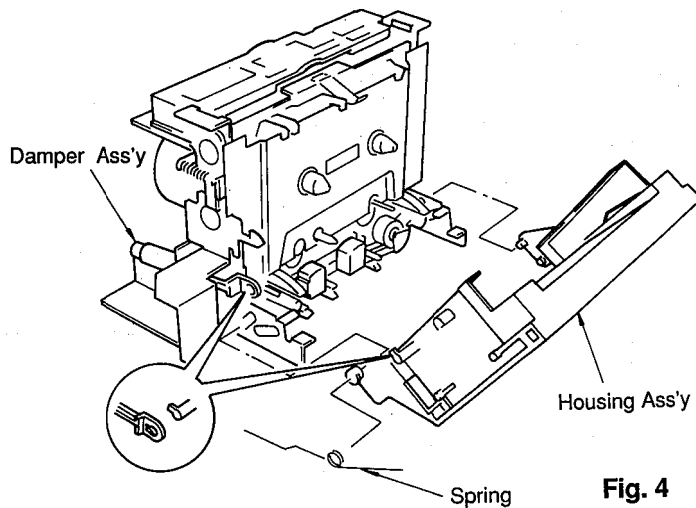

Fig. 4

5. Removal of Pinch Roller

- a. Detach the hook in fig. 5 and remove the pinch roller.

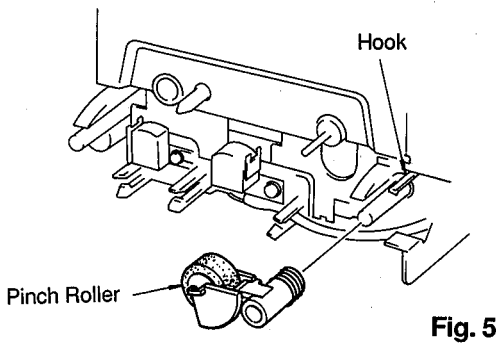
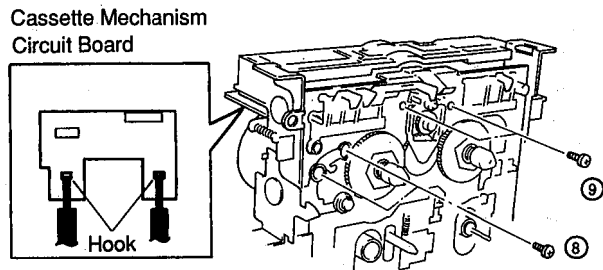

Fig. 5

8. Removal of Capstan Motor and Reel Motor

- a. Remove 2 screws (8) in fig. 8 and then remove the capstan motor.
- b. Remove 2 screws (9) in fig. 8 and detach 2 hooks of the cassette mechanism circuit board, then remove the reel motor.



6. Removal of Heads

- a. Remove 2 screws (5) in fig. 6 and then remove the Recording/Playback Head.
- b. Remove 2 screws (6) in fig. 6 and then remove the Erase Head.

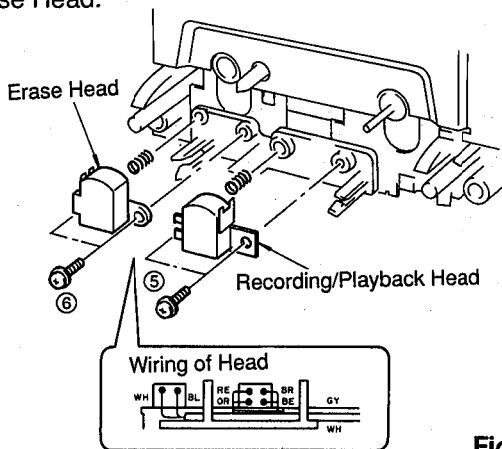

Fig. 6

9. Removal of Main Circuit Board(1)

- a. Remove 4 screws (10) and detach 4 hooks in fig.9.

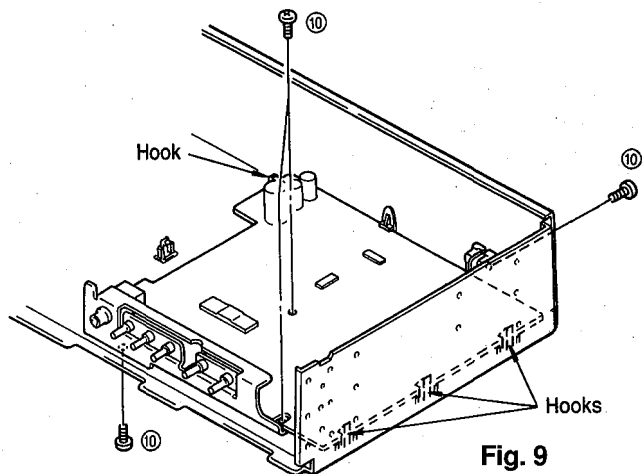

Fig. 9

7. Removal of Back Plate

- a. Remove 1 screw (7) and 1 plastic rivet (C) in fig. 7 and then remove the back plate.

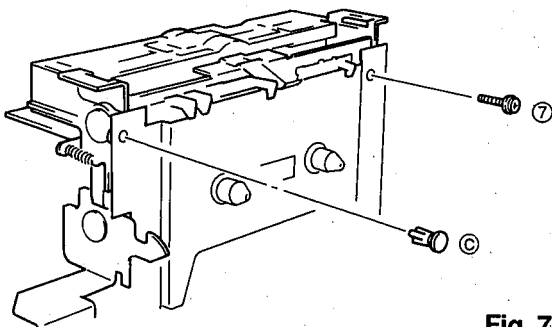

Fig. 7

ADJUSTMENTS

1. Before Adjustment:

- Make sure that AC line voltage is within:

Models	AC line voltage
U, C	120 V ± 10%
G, B	230 V ± 10%
A,	240 V ± 10%

- Since head magnetization, dust accumulation, etc. are likely to cause errors in the various characteristics, it is very important to keep the heads properly demagnetized and clean.

2. Instruments required

- Audio frequency oscillator (AF OSC)
- ACVM or dual channel ACVM
- Wow/flutter meter
- Torque meter
TW-2111A (TX911580): FWD. Torque & Back Tension Torque
CT160L (TX911120): FF. Torque & REW. Torque
- DCVM
- Oscilloscope

3. Test tape required

- MTT-111N (TX911650): Tape Speed (3 kHz)
- MTT-114N (TX911680): Azimuth (10 kHz)
- MTT-212N (TX911660): Playback Level (250nWb/m)
- MTT-256 (TX911300): Playback Frequency Response (Normal)
- MTT-356 (TX911310): Playback Frequency Response (High)
- Reference tape
Normal (LH) : TDK AC225(VU167200)
High (CrO₂) : TDK SA-60 or TDK AC514 (VU167300)
METAL : TDK AC713(VU167400)

4. Data backup at power off (AC plug)

μ-COM backup data (about 2 weeks): Power ON/OFF, NR (MPX) MODE, TAPE COUNTER VALUE, TAPE TUNING

MECHANISM ADJUSTMENT

Note: The damper must be removed before you perform steps 1 and 2 of the procedure, because the torque meter is hidden behind the damper (Fig. a).

* How to remove the damper from the housing ass'y.

1. Depress the damper with fingers, and the damper can be removed from the shaft in fig. b
2. Take out the damper, lifting it up.

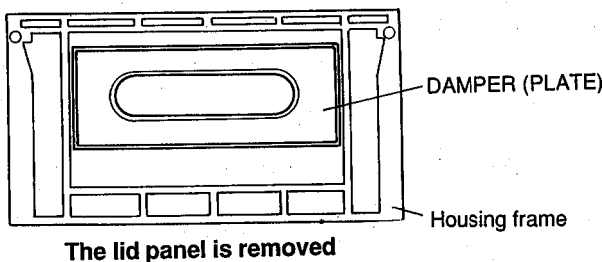

Fig. a

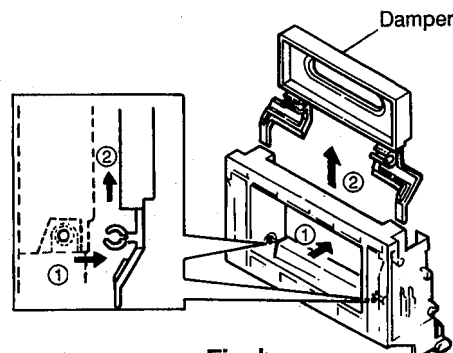
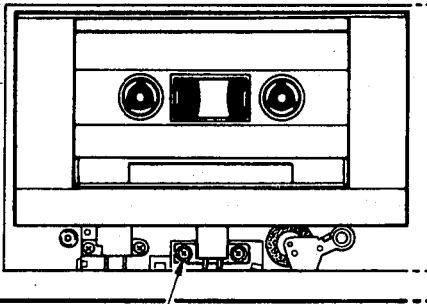

Fig. b

0 dB = 250 nWb/m (315 Hz) = -5 dBV (Line out terminal level)

Step	Item to be Adjusted	Tape	Instrument required	Mode	Adjustment part	Rating	Remarks
1	Check each torque		Torque meter TW-2111A CT160L	PLAY FF REW		Take-up torque: 25 g·cm~70g·cm Back tension: 1.5g·cm~6g·cm FF, REW torque: more than 70g·cm	
2	Check FF, REW take up time	AC-225 (C-60)		FF REW		90 ± 15 seconds	
3	Azimuth	MTT-114 (10 kHz, -10 dB)	ACVM Oscilloscope	PLAY	Azimuth adjustment screw (Fig. A)	Playback level is maximum and phase difference should be minimum. (Fig. B)	After the adjustment make sure to apply screw lock paint.

Step	Item to be Adjusted	Tape	Instrument required	Mode	Adjustment part	Rating	Remarks
4	Tape speed	MTT-111N 3 kHz, -10 dB	Wow/flutter meter of Frequency counter	PLAY	Potentiometer at the back of the capstan motor. (Fig. C)	3005 Hz \pm 15Hz	• Perform adjustment at the position where the test tape is advanced/rewound to the middle.
5	Wow/flutter	MTT-111N 3 kHz, -10 dB	Wow/flutter meter	PLAY		Less than 0.14% (EIAJ, WRMS)	



Azimuth adjustment screw

Fig. A

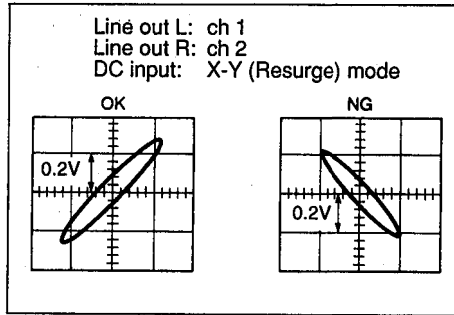

Fig. B

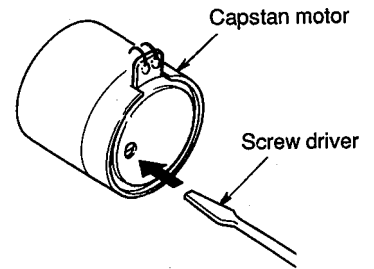

Fig. C

■ ELECTRICAL ADJUSTMENT

* Standard level of this machine is that 250 nWb/m is 0 dB. (-5 dBV at LINE OUT)

● PLAYBACK ADJUSTMENT

Step	Adjustment items	Tape	Instrument required	Mode	Adjustment part	Point of measurement	Adjustment method	Specification
1	Playback Level (315 Hz)	MTT-212N (0 dB)	ACVM	PLAY	VR3 (Lch) VR4 (Rch)	LINE OUT	When MTT-212N is played back, adjust VR so that output level becomes the specified Value.	-5dBV \pm 0.3 dBV
2	Playback EQ Level (10 kHz)	MTT-114N (10 kHz, -10 dB)	ACVM	PLAY	VR1 (Lch) VR2 (Rch)	LINE OUT	When MTT-114N is played back, adjust VR so that output level becomes the specified Value.	-15dBV \pm 1 dBV
3	Confirmation of Playback Frequency Response	MTT-256 (Normal: 3180 μ s + 120 μ s) MTT-356 (High: 3180 μ s + 70 μ s)	ACVM Oscilloscope	PLAY		LINE OUT	Make sure that level of LINE OUT jack is within the specification of Fig. D when test tape is played back.	0 dB \pm 4 dB

● PLAYBACK FREQUENCY RESPONSE

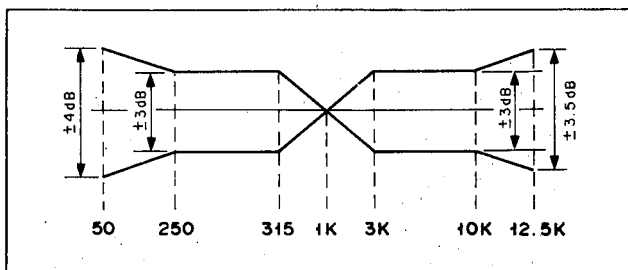

Fig. D

● RECORDING ADJUSTMENT
(BIAS ADJ. VR and PLAY TRIM VR Center position, if not specified otherwise)

Step	Adjustment Items	Test tape	Instrument required	Mode	Adjustment Terms	Measurement point	Adjustment point	Rating
1	Meter Level	Normal (AC225) (LH)	ACVM AF OSC	REC/ PAUSE PEAK HOLD OFF TEST MODE	1. Set FL display test mode to meter peak hold OFF. 2. Set REC LEVEL knob to maximum. 3. Input 315 Hz signal to LINE IN jack from AF OSC. Adjust output level of AF OSC so that the level of LINE OUT jack becomes -5 dBV.	Peak Level Meter	VR9 (Lch) VR10 (Rch)	Adjust VR to the minimum level where 0 dB segment (red) of peak level meter lights up.
2	Bias Oscillation Level (HXPRO)	HIGH (AC514) (CrO ₂)	DCVM	REC	1. Enter REC mode. 2. Connect DCVM between each TP-GND.	TP1-GND TP2-GND	L3 (Lch) L4 (Rch)	Adjust L3 and L4 so that DC voltage becomes minimum.
3	Recording Level	HIGH (AC514) (CrO ₂)	ACVM AF OSC	REC/ PAUSE	1. Set REC LEVEL knob to maximum. 2. Enter REC/PAUSE mode. 3. Input 315 Hz signal to LINE IN jack from AF OSC. Adjust the output level of AF OSC so that level of LINE OUT jack becomes -25 dBV.	LINE OUT	VR5 (Lch) VR6 (Rch)	Adjust VR so that level of LINE OUT -25 ± 0.3dBV at playback.
				REC	4. Record the above-mentioned signal.			
				PLAY-BACK	5. Playback the recorded tape.			
4	Recording Bias	HIGH (AC514) (CrO ₂)	ACVM AF OSC	REC/ PAUSE	1. Set REC LEVEL knob to maximum. 2. Enter REC/PAUSE mode. 3. Input 12.5 kHz signal to LINE IN jack from AF OSC. Adjust the output level of AF OSC so that level of LINE OUT jack becomes -25 dBV.	LINE OUT	VR7 (Lch) VR8 (Rch)	Adjust VR so that level of LINE OUT jack satisfies Fig. E when a tape, recorded at -25 ± 0.5 dBV at each frequency, is playback.
				REC	4. Record the above-mentioned signal.			
				PLAY-BACK	5. Playback the recorded tape.			

FL DISPLAY TEST MODE

Enter the TEST MODE by pressing POWER SW while pressing the RESET KEY when the power is OFF.

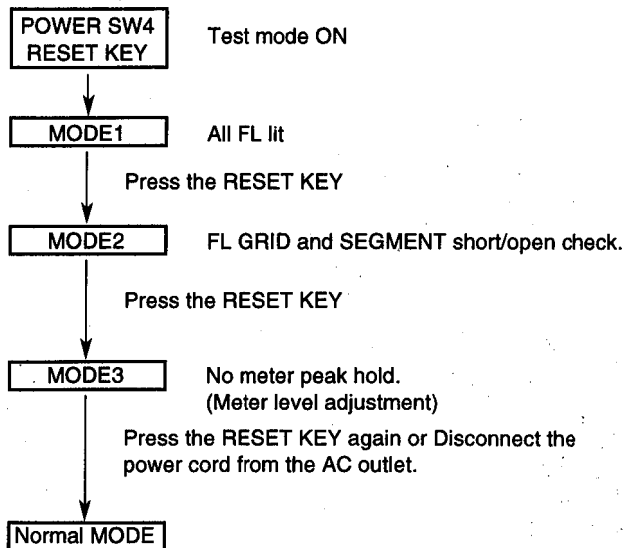

● TOTAL FREQUENCY RESPONSE (-15dBV)

Table 1

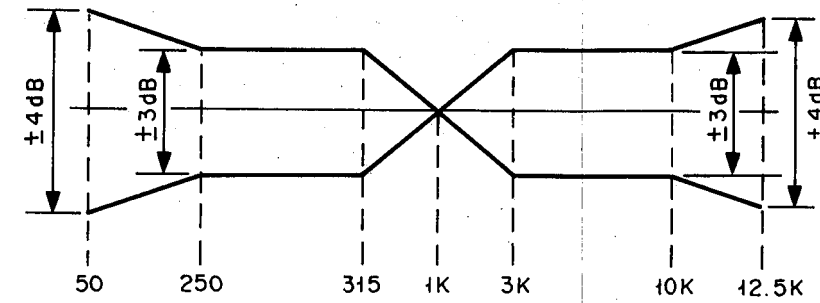

NR : NR off/Dolby B NR on/Dolby C NR on
(B&C NR : Reference level must be recorded level.)
TAPE : Normal(LH)/High(CrO₂)/METAL

Fig.E

● TEST POINT

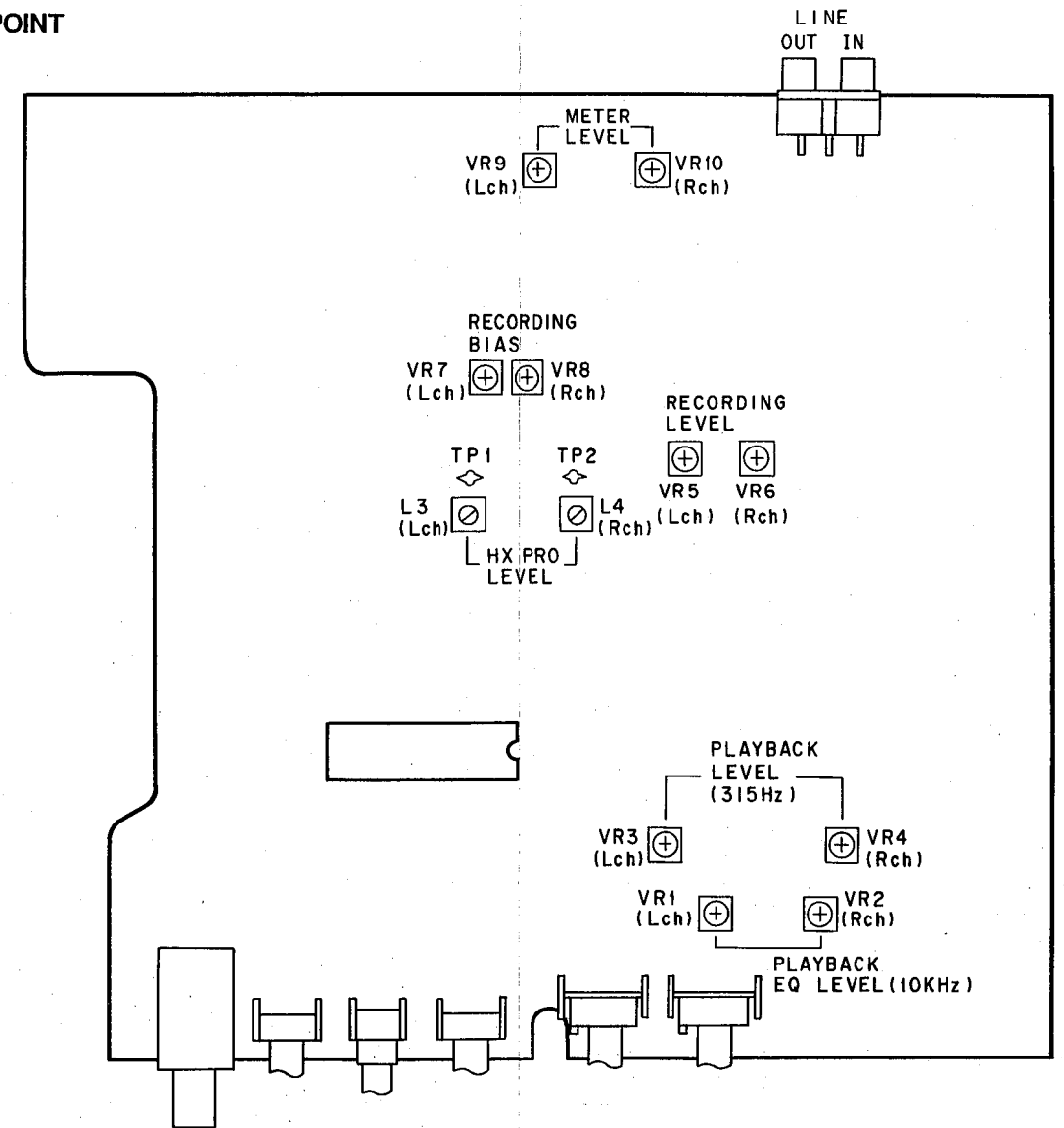

μ-COM DATA
IC12 : LC65204A
4 bit μ-COM

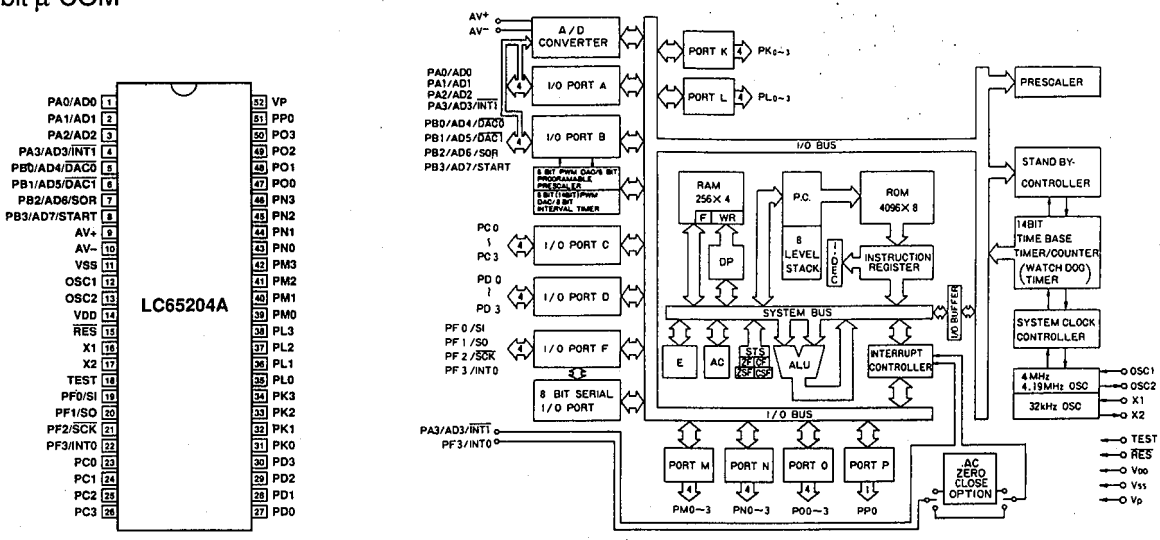

NO	PORT	FUNCTION	LOGIC	NO	PORT	FUNCTION	LOGIC
1	PA0	OPERATION KEY (1)	A/D	27	PD0	LINE MUTE	H:ON
2	PA1	OPERATION KEY (2)	A/D	28	PD1	REC MUTE	H:ON
3	PA2	METER INPUT (L)	A/D	29	PD2	DOLBY 1 (DOLBY ON/OFF)	H:OFF
4	PA3	METER INPUT (R)	A/D	30	PD3	DOLBY 2 (DOLBY C ON/OFF)	H:OFF
5	PB0	MECHA SW	A/D	31	PK0	MPX FILTER	H:ON
6	PB1	MECHA SW & TIMER	A/D	32	PK1	REC/PB SELECT	H:PB
7	PB2	REEL PULSE		33	PK2	FL FILAMENT ON/OFF	H:ON
8	PB3	POWER PULSE		34	PK3	FL SEGMENT 9	H:ON
9	AV+	+5V		35	PL0	FL SEGMENT 8	H:ON
10	AV-	GND		36	PL1	FL SEGMENT 7	H:ON
11	VSS	GND		37	PL2	FL SEGMENT 6	H:ON
12	OSC1	4MHz		38	PL3	FL SEGMENT 5	H:ON
13	OSC2	4MHz		39	PM0	FL SEGMENT 4	H:ON
14	VDD	+5V		40	PM1	FL SEGMENT 3	H:ON
15	RES	RESET		41	PM2	FL SEGMENT 2	H:ON
16	X1	+5V		42	PM3	FL SEGMENT 1	H:ON
17	X2	OPEN		43	PN0	FL DIGIT 1	H:ON
18	TEST	GND		44	PN1	FL DIGIT 2	H:ON
19	PF0	PORT EXPANDER IC (CLOCK)		45	PN2	FL DIGIT 3	H:ON
20	PF1	PORT EXPANDER IC (DATA)		46	PN3	FL DIGIT 4	H:ON
21	PF2	BIAS	H:ON	47	PO0	FL DIGIT 5	H:ON
22	PF3	REMOCON INPUT		48	PO1	FL DIGIT 6	H:ON
23	PC0	MECHA DRIVE	CM	49	PO2	FL DIGIT 7	H:ON
24	PC1	MECHA DRIVE	SOLENOID	50	PO3	FL DIGIT 8	H:ON
25	PC2	GND (47k)		51	PP0	FL DIGIT 9	H:ON
26	PC3	HEAD SELECT	H:REC	52	Vp	-21V	

● OUTPUT OF EXPANDER (IC13) PORT

4 PIN	LH	H:ON	10 PIN	LEVEL 3
5 PIN	HIGH	H:ON	11 PIN	LEVEL 4
6 PIN	METAL	H:ON	12 PIN	BIAS 1
7 PIN	70	H:ON	13 PIN	BIAS 2
8 PIN	TAPE TUNING		14 PIN	BIAS 3
9 PIN	LEVEL 1		15 PIN	BIAS 4

● CONDITION OF OUTPUT PORT VERSUS MODE

NO	NAME	STOP	PLAY	FF/REW	SEARCH	REC PAUSE	REC
21	BIAS	H	H	H	H	H	L
27	LINE MUTE	L	L	H	L	H	H
28	REC MUTE	H	H	H	H	H	L
32	REC/PB SELECT	H	H	H	H	L	L

BLOCK DIAGRAM

